



- High Accuracy
- Broad Bandwidth
- Low Zero-drift

Shenzhen Hangzhi Precision Electronics Co. Ltd.

Product Model: IIT300

Measurement Range: DC±300A

Accuracy: 0.02%

IIT300 Industrial Control Level Current Transducer

IIT300 has a high gain and measurement accuracy in the full bandwidth range, due to the application of the multi-point zero-flux technology system and high-frequency ripple sensing channel on top of currently existing DC sensor technology.

The multi-point zero-flux technology system secures the high accuracy by utilizing the technology combination of exciting magnetic flux closed-loop control, self-excited magnetic flux gate and multi-closed-loop control that realizes the closed-loop control between excitation magnetic flux and AC/DC magnetic flux generated by primary current, while the high-frequency ripple sensing channel allows the sensor to have the high performance over the full bandwidth range.

Product photo





- High Accuracy
- Broad Bandwidth
- Low Zero-drift

Shenzhen Hangzhi Precision Electronics Co. Ltd.

Product Model: IIT300
Measurement Range: DC±300A
Accuracy: 0.02%

Key Technologies

- ◇ Excitation closed-loop control technology
- ◇ Self-excitation demagnetization technology
- ◇ Multi-point zero-flux technology
- ◇ Temperature control compensation technology
- ◇ Multi-range automatic switching technology

Features

- ◇ Insulated measurement between primary and secondary side
- ◇ Excellent linearity and accuracy
- ◇ Extremely low temperature drift
- ◇ Extremely low zero drift
- ◇ Broad band and low response time
- ◇ Strong anti-electromagnetic interference

Application Domain

- ◇ Medical Equipment: Scanner, MRI
- ◇ Power Industry: Converter, Inverter
- ◇ Renewable Energy: Photovoltaic, Wind energy
- ◇ Testing Instrument: Power analyzer, High-precision power supply
- ◇ Smart Power Grid: Power generation and battery monitoring, Medium low voltage substation
- ◇ Industry Control: Industrial motor drive, UPS, Welding, Robot, Hoist, Elevator, Ski lift
- ◇ Rail Transit: EMU, Metro, Trolley car
- ◇ Ship: Electric driven ship
- ◇ Car: Electric car

Electrical Performance

Parameter	Symbol	Measuring Conditions	Min	Typ	Max	Unit
Primary nominal direct current	I _{PN_DC}	—	—	±300	—	Adc
Primary nominal RMS current*	I _{PN_AC}	—	—	212	—	Aac
Primary current, measuring range	I _{PM}	—	—	—	±360	Adc
Power supply voltage DC	U _C	—	±14.2	±15	±15.8	V
Current consumption	I _C	Rated primary current	±30	±180	±210	mA
Conversion ratio	K _N	Primary/secondary	2000:1	2000:1	2000:1	—
Secondary nominal RMS current	I _{SN}	Rated primary current	—	±0.15	—	A
Secondary burden resistance	R _M	—	0	10	20	Ω

* refers to AC effective value



- High Accuracy
- Broad Bandwidth
- Low Zero-drift

Shenzhen Hangzhi Precision Electronics Co. Ltd.

Product Model: IIT300
Measurement Range: DC± 300A
Accuracy: 0.02%

Accuracy Measurement

Parameter	Symbol	Measuring Conditions	Min	Typ	Max	Unit
Accuracy	X_G	Input direct current, full temperature range	—	—	0.02	%
Linearity error	ϵ_L	Full temperature range	—	—	20	ppm
Zero offset current	I_{OT}	@25°C	—	—	±5	μA
Zero offset current	I_o	Full temperature range	—	—	±10	μA
Step response time to 90% I_{PN_DC}	t_r	di/dt of 100A/μs	—	—	1	μs
di/dt accurately followed	di/dt	—	200	—	—	A/μs
Frequency bandwidth (-3dB)	BW	—	0	—	100	kHz

Safety Characteristics

Parameter	Symbol	Measuring Conditions	Value	Unit
Insulation voltage / Between primary and secondary	Ud	50Hz, 1min	5	KV
Impulse withstand voltage / Between primary and secondary	Uw	50μs	10	KV
Creepage distance / Between primary and shield	d _{CP}	—	11	mm
Clearance distance / Between primary and shield	d _{CI}	—	11	mm
Comparative tracking index	CTI	IEC-60112	600	V

General Characteristics

Parameter	Symbol	Measuring Condition	Min	Typ	Max	Unit
Ambient operating temperature	T_A	—	-40	—	+85	°C
Ambient storage temperature	T_S	—	-40	—	+85	°C
Relative humidity	RH	—	20	—	80	%
Mass	M	—	—	420±50	—	g



- High Accuracy
- Broad Bandwidth
- Low Zero-drift

Shenzhen Hangzhi Precision Electronics Co. Ltd.

Product Model: IIT300

Measurement Range: DC± 300A

Accuracy: 0.02%

Safety



Cautions

This specifications documents provide users with relevant precautions for installation, commissioning, operation and maintenance. Please read carefully before installation and use. This manual is provided with the product, please keep it in a proper place for reference during maintenance.

The device must be used according to the manufacturer specifications, otherwise there are risks to damage the device, other equipment connected, and safety risks to operators.

Always inspect the device and its accessories, and confirm they are in good status before energize the device.

If you find any damage to the device housing, fixing, power cord, connecting cables, or connected equipment, immediately disconnect the device from the power source.

If you have concerns about the safe operation of the equipment, you should immediately shut down the equipment and the corresponding accessories, and get in touch with the technical support department of our company as soon as possible to communicate and solve the problem.



Danger

The current sensor is not allowed to be used when the secondary output is open-circuited, that is, when the primary has current or the sensor is powered on, the secondary output terminal is not allowed to be disconnected; only when the bus has no current and the sensor is not powered on, the current output terminal of the sensor can be disconnected . Otherwise, high voltage may be induced and there is a danger of electric shock or equipment damage.

When you need to move the product, please be sure to cut off the power first and unplug all the connecting cables connected to it.



- High Accuracy
- Broad Bandwidth
- Low Zero-drift

Shenzhen Hangzhi Precision Electronics Co. Ltd.

Product Model: IIT300
Measurement Range: DC±300A
Accuracy: 0.02%

Operating Status Instructions

◇ Normal status:

The green light indicator is on when the device is running normally:

After the device is powered on, the green indicator is on when the device is running normally. When the green light is off, you should check whether the power supply of the transducer is normal as the first step.

◇ Fault status:

The green light is blinking when the current overloads.

Trouble-shooting:

If the power supply is normal, the green light indicator keeps on blinking, then the primary current is over the specified measurement range and the transducer will be in overload mode. In this mode, the transducer will be working in non-zero flux mode, the secondary and primary currents are not in proportion. When the current recovers to the specified measurement current range, the current transducer returns to normal, green light indicator will be on.

Connection system

1. Phoenix terminal pin function definition

Pin	1	2	3	4
Definition	+15V Supply	-15V Supply	I_Output	GND

IIT Series Transducer

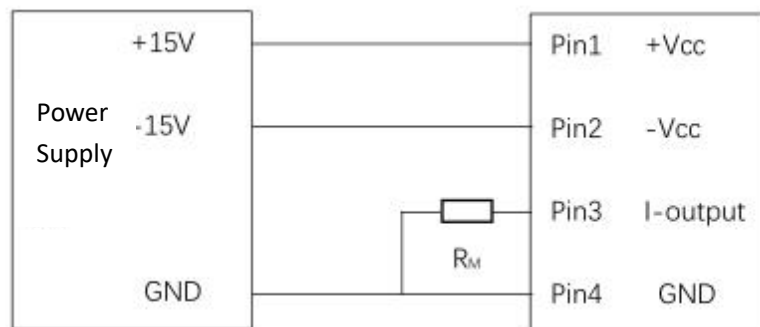

Test instruction:

The primary current I_P can be obtained by measuring the test current I_s flowing through R_M or the voltage U_R across R_M :

$$I_P = K_N * I_S = K_N * (U_R / R_M)$$



- High Accuracy
- Broad Bandwidth
- Low Zero-drift

Shenzhen Hangzhi Precision Electronics Co., Ltd.

Product Model: IIT300
Measurement Range: DC± 300A
Accuracy: 0.02%

Dimensions

Unit: mm

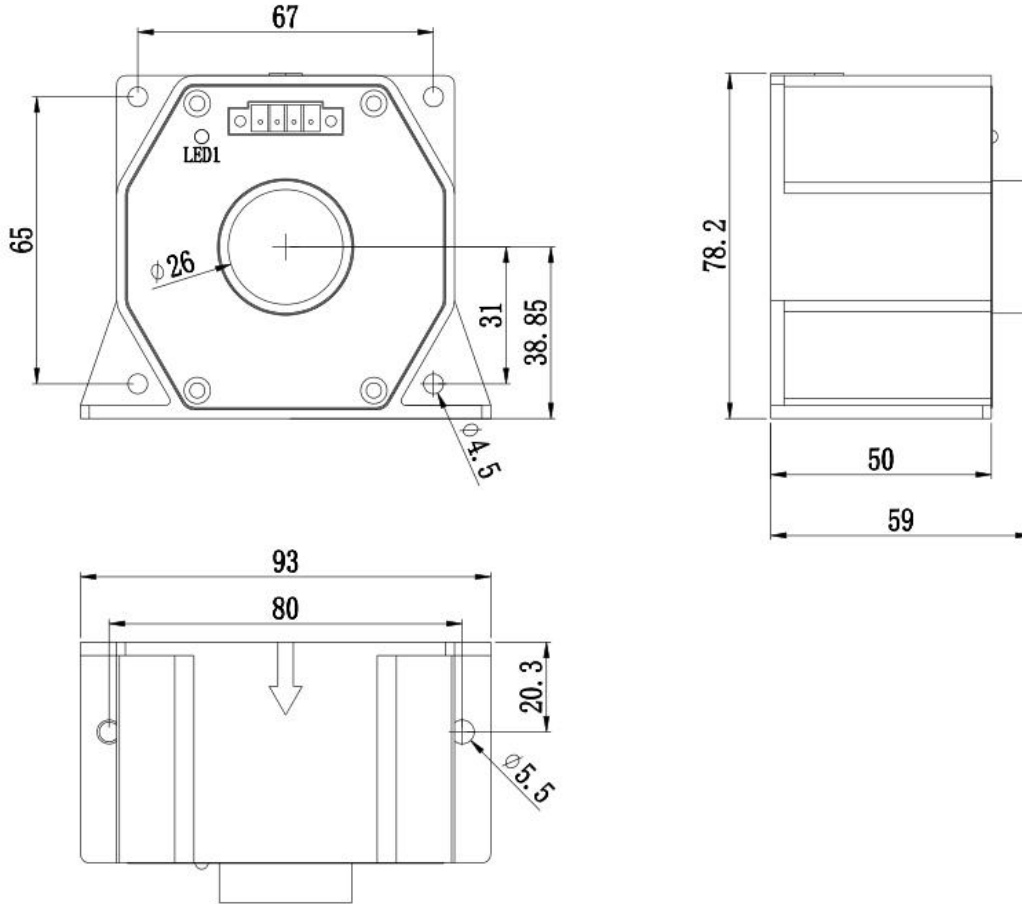

Packing List & Dimensions

Package dimensions (L x W x H): 120mm x 103mm x 96mm

Item	Description	Quantity	Comments
IIT300	Current Transducer	1	/